

## Features

- Pressure ranges to 20,000 psi (1400 bar)
- Accuracy better than 0.015% of reading. (Increased accuracy option of 0.008%.)
- Mineral oil and distilled water models
- Dual piston models allow calibration over a wide range
- Psi, bar, kgf/cm<sup>2</sup>, kPa and MPa ranges available

The Pressurements 3000 Series is the culmination of over 50 years experience in the production and design of primary pressure standards. With features designed to improve accuracy and performance, increase reliability and simplify operation these deadweight testers can be used to calibrate virtually any pressure sensing device, including transducers, transmitters, gauges or pressure switches.

Each instrument is supplied with a detachable lid which makes it neat, compact and easily portable. The weight masses are stored in a high-quality case with a self locking mechanism to protect them during transit. All units are provided with a traceable certificate of accuracy, weight mass details, 1/8, 1/4, 3/8 and 1/2 NPT or BSP female adaptors, operating fluid (where applicable) and spare seals.

The piston/cylinder assemblies are manufactured to the very highest standards with certified accuracies traceable to international standards laboratories such as the National Institute of Standards and Technology (NIST).

---

# P3000 Series

## Hydraulic Deadweight Testers

### Models P3100 & P3200

The P3000 Series is a Pressurements product. Pressurements has joined other GE high-technology sensing businesses under a new name—GE Industrial, Sensing



## Hydraulic Deadweight Testers Models P3100 and P3200

### Operating Principle

Deadweight testers are the primary standard for pressure measurement. Utilizing the well proven piston-gauge system consisting of a vertically mounted, precision lapped piston and cylinder assembly, accurately calibrated weight masses (Force) are loaded on the piston (Area), which rises freely within its cylinder. These weights balance the upward force created by the pressure within the system.

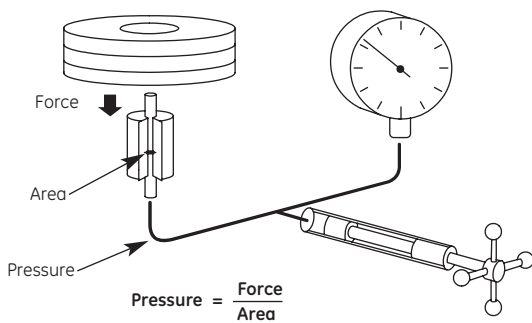

The pressure is measured when placed on a correctly spinning and floating piston. The total pressure measured is the summation of the weights plus the piston weight carrier assembly.

### Instrument Base

There are three basic variations in the hydraulic offering; single low pressure, single high pressure and dual piston models. Pressure is generated and controlled by means of a high quality screw press located on the front of the tester. A built-in hand pump is included as standard for all hydraulic models to prime the system and accommodate large volume requirements.

### Piston/Cylinder Assemblies

The piston/cylinder assembly is the heart of each deadweight tester. They are manufactured from materials that provide stability, durability, and low thermal coefficients and distortion. Our experience and knowledge of piston/cylinder production and calibration ensure the precision and performance required for today's demanding calibration requirements.

### Weight Masses

Standard weight masses are series 3 non-magnetic austenitic stainless steel. Each mass is marked with the serial number of the instrument and the nominal pressure value relative to the high or low-pressure piston, when applicable. Optional fractional weights are stainless steel and/or solution heat treated aluminum.

### Gravity Correction

Gravity varies significantly with geographical location and this variation has a direct effect on the force of the weights and the accuracy of the deadweight tester. Each instrument can be calibrated to local gravity at no extra cost. If unspecified, instruments will be calibrated to Standard Gravity at 980.665 cm/s<sup>2</sup>.

### Features

- Dual piston models for calibration over a wide pressure range
- Built-in lever style hand pump now standard on all hydraulic models
- Mounted spirit level and adjustable feet
- High quality screw press for fine pressure control
- Test station design with O-rings eliminates the need for PTFE tape or wrenches
- Acrylic reservoir provides visibility of fluid level and quality
- Improved case with spring-loaded latches for hood
- Built-in drain plug to remove old fluid
- Sturdy weight box with hinged lid and side handles for easy transport

Oil Operated - Single PCU		Oil Operated - Dual PCU	
Model #	Pressure Range	Model #	Pressure Range
P3111-1	1 to 35 bar	P3123-1	1 to 350 bar
-2	1 to 35 kgf/cm <sup>2</sup>	-2	1 to 350 kgf/cm <sup>2</sup>
-3	10 to 500 psi	-3	10 to 5,000 psi
-4	100 to 3,500 kPa	-4	100 to 35,000 kPa
-5	0.1 to 3.5 MPa	-5	0.1 to 35 MPa
P3112-1	4 to 140 bar	P3124-1	1 to 700 bar
-2	4 to 140 kgf/cm <sup>2</sup>	-2	1 to 700 kgf/cm <sup>2</sup>
-3	40 to 2,000 psi	-3	10 to 10,000 psi
-4	400 to 14,000 kPa	-4	100 to 70,000 kPa
-5	0.4 to 14 MPa	-5	0.1 to 70 MPa
P3113-1	10 to 350 bar	P3125-1	1 to 1,100 bar
-2	10 to 350 kgf/cm <sup>2</sup>	-2	1 to 1,100 kgf/cm <sup>2</sup>
-3	100 to 5,000 psi	-3	10 to 16,000 psi
-4	1,000 to 35,000 kPa	-4	100 to 110,000 kPa
-5	1 to 35 MPa	-5	0.1 to 110 MPa
P3114-1	20 to 700 bar		
-2	20 to 700 kgf/cm <sup>2</sup>		
-3	200 to 10,000 psi		
-4	2,000 to 70,000 kPa		
-5	2 to 70 MPa		
P3115-1	20 to 1,100 bar		
-2	20 to 1,100 kgf/cm <sup>2</sup>		
-3	200 to 16,000 psi		
-4	2,000 to 110,000 kPa		
-5	2 to 110 MPa		
P3116-1	20 to 1,400 bar		
-2	20 to 1,400 kgf/cm <sup>2</sup>		
-3	200 to 20,000 psi		
-4	2,000 to 140,000 kPa		
-5	2 to 140 MPa		

Water Operated - Single PCU		Water Operated - Dual PCU	
Model #	Pressure Range	Model #	Pressure Range
P3211-1	1 to 35 bar	P3223-1	1 to 350 bar
-2	1 to 35 kgf/cm <sup>2</sup>	-2	1 to 350 kgf/cm <sup>2</sup>
-3	10 to 500 psi	-3	10 to 5,000 psi
-4	100 to 3,500 kPa	-4	100 to 35,000 kPa
-5	0.1 to 3.5 MPa	-5	0.1 to 35 MPa
P3213-1	10 to 350 bar	P3224-1	1 to 700 bar
-2	10 to 350 kgf/cm <sup>2</sup>	-2	1 to 700 kgf/cm <sup>2</sup>
-3	100 to 5,000 psi	-3	10 to 10,000 psi
-4	1,000 to 35,000 kPa	-4	100 to 70,000 kPa
-5	1 to 35 MPa	-5	0.1 to 70 MPa
P3214-1	20 to 700 bar		
-2	20 to 700 kgf/cm <sup>2</sup>		
-3	200 to 10,000 psi		
-4	2,000 to 70,000 kPa		
-5	2 to 70 MPa		

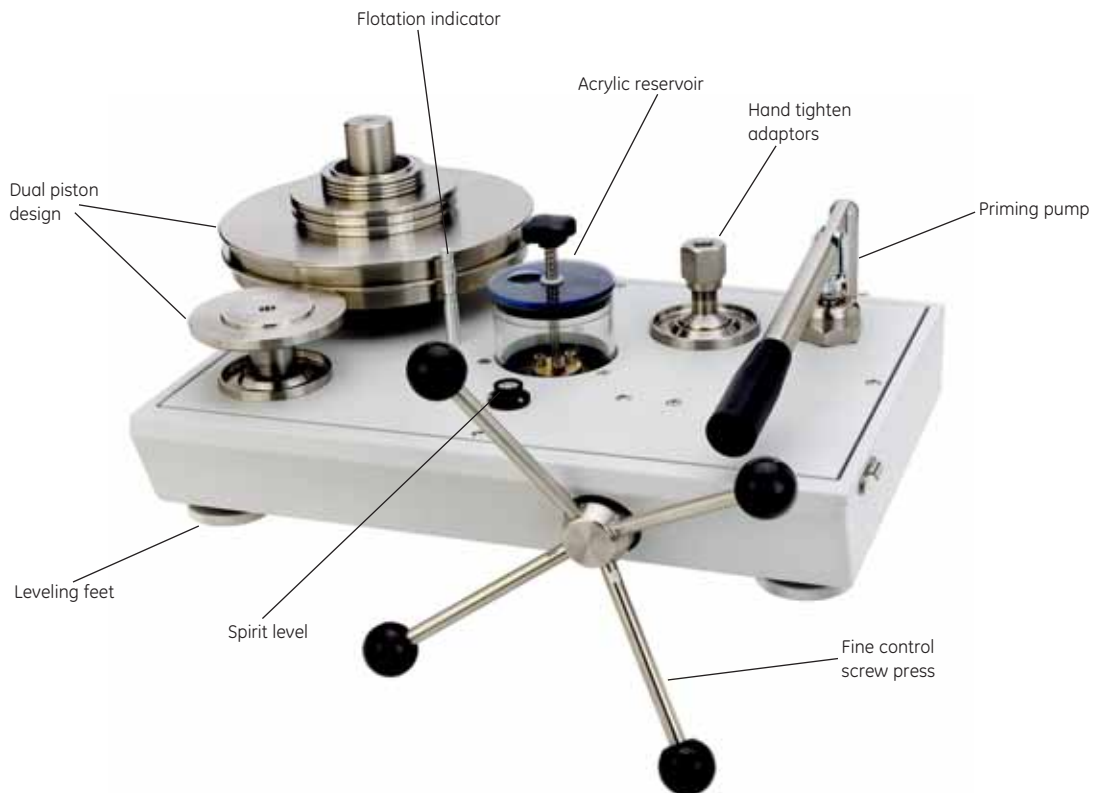

# P3000 Series Specifications

## Pressure Ranges

- Oil operated Ranges to 20,000 psi (1400 bar)
- Distilled water operated Ranges to 10,000 psi (700 bar)

## Accuracy\*

±0.015% of reading (±0.008% optional)

\*Accuracy based on % of reading from 10% to 100% of the piston range when used in accordance with the corrections found on the calibration certificate. Below 10% ± (accuracy class) × 10% of the piston range.

## Materials of Construction

Standard weight material	Series 3 non-magnetic austenitic stainless steel
Weight density	7.8 g/cm <sup>3</sup>
Optional fractional weights	Solution heat treated aluminum
Weight density	2.7 g/cm <sup>3</sup>
Piston material	Tungsten carbide with nickel binder Density- 15.0 g/cm <sup>3</sup>
Cylinder material	Hardened martensitic steel Tungsten carbide (water above 500 psi, 35 bar)
Thermal coefficients of expansion	Oil piston/cylinder 16.5 ppm/°C Water (above 500 psi, 35 bar) 11 ppm/°C

## General

Test port adaptors	1/8, 1/4, 3/8 and 1/2 NPT or BSP
Instrument weight	36 lbs (16 kg)
Instrument size	(W × D × H) 17.5 in × 12 in × 8.5 in (440 mm × 300 mm × 215 mm)
Mass set weight (typical)	80 lbs (36 kg)
Reservoir volume	150 cc
Screw press displacement	5.5 cc
Pump displacement	4.7 cc per stroke
O-ring seal materials	Buna N as standard, Viton and EPDM available

## Weight Increments\*

### Minimum Standard Weight Increments

Up to 500 psi (35 bar)	1 psi (0.1 bar)
500 to 5000 psi (35 to 350 bar)	10 psi (1 bar)
5000 to 20,000 psi (350 to 1400 bar)	20 psi (2 bar)
Model P3112	1 psi (0.1 bar)

### Optional Fractional weights

Up to 500 psi (35 bar)	0.1 psi (0.01 bar)
500 to 5000 psi (35 to 350 bar)	1 psi (0.1 bar)
5000 to 20,000 psi (350 to 1400 bar)	2 psi (0.2 bar)

\*For a complete weight breakdown as provided with each model, please refer to document ER4012.

## Operating Fluids

Mineral oil Shell spindle oil 22, our reference 55-655,  
viscosity 40 cs@ 20°C  
Distilled or deionized water

## Options

### A) PressCal Software

Windows-based software program that allows users to easily apply all necessary corrections to enhance the deadweight tester performance. Calibration details are then stored and/or used to automatically create a calibration certificate.

*PressCal is provided as standard with all 0.008% instruments.*

B) Instruments can be supplied for use with Skydrol or brake fluids. Due to the aggressive nature of these fluids the standard nitrile seals and the acrylic reservoir tube will be replaced by either Viton or EPDM seals (as applicable) and an aluminum reservoir tube. For these or any other specialty fluid applications, please consult the factory.



©2006 GE. All rights reserved.  
920-368B

All specifications are subject to change for product improvement without notice. GE® is a registered trademark of General Electric Co. Other company or product names mentioned in this document may be trademarks or registered trademarks of their respective companies, which are not affiliated with GE.